

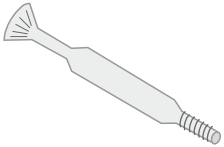









Accessori / Equipment	Pos.	Pezzi / Pcs	Descrizione / Description
 	5	9	Perno per eccentrico Cam bolt
 	6	4	Eccentrico x sp.25mm Cam x th.25mm
 	7	5	Eccentrico x sp.18mm Cam x th.18mm
 	8	9	Tappino copri eccentrico Cam covercap
 	9	4	Piedino Foot

Istruzioni di montaggio / Assembly Instructions

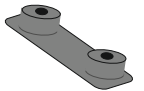

Posizionare i fianchi dx (2) e sx (3) su una superficie piana, con i fori rivolti verso l'alto. Inserire i perni (5) e gli eccentrici sp.25mm (6) sui fianchi. Gli eccentrici vanno inseriti con la freccia rivolta verso il bordo più vicino come mostrato in figura. Avvitare i perni sino a fine corsa.

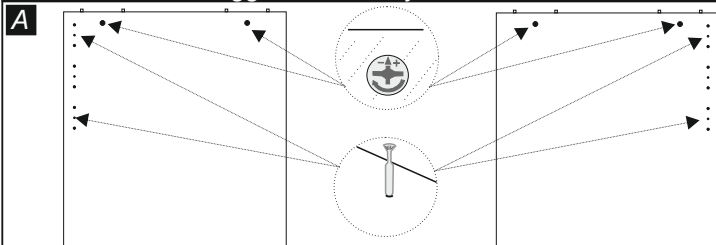
Place the rh side (2) and lh side (3) on a flat surface, with the holes facing upwards. Insert the bolts (5) and the cams th.25mm (6) on the sides. The cam must be inserted with the arrow pointing toward the nearest edge as shown in the figure. Screw the bolt until the end of the stroke.

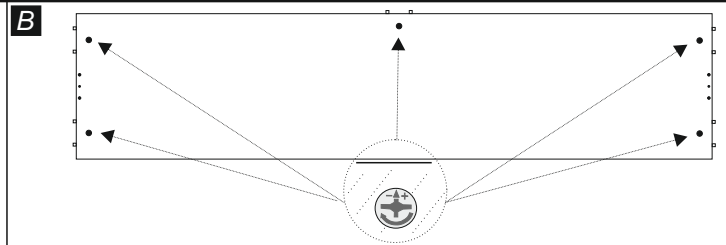

Posizionare la tramezza (4) su una superficie piana con i fori rivolti verso l'alto. Inserire gli eccentrici sp.18mm (7) sulla tramezza. Gli eccentrici vanno inseriti con la freccia rivolta verso il bordo più vicino, come mostrato in figura.

Place the partition shelf (4) on a flat surface with the holes facing upwards. Insert the cams th.18mm (7) on the partition shelf. The cam must be inserted with the arrow pointing toward the nearest edge, as shown in the figure.

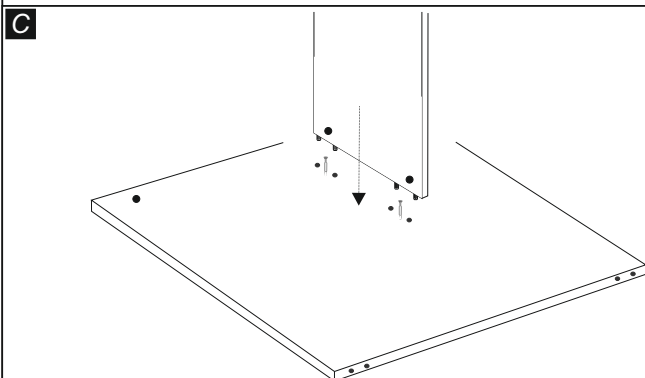

Sistemare la tramezza (4) sul fianco sx (3), infilandolo sui perni per eccentrico inseriti precedentemente.

Place the partition shelf (4) on the lh side (3), inserting it on bolts inserted previously.

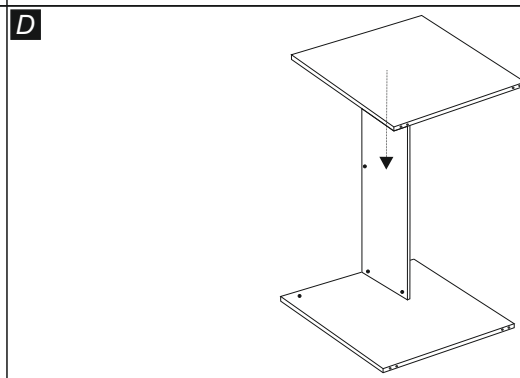

Sistemare ora il fianco dx (2) sulla tramezza (4), infilandolo con i perni per eccentrico inseriti precedentemente.

Now place the rh side (2) on the partition shelf (4), inserting it with the bolts inserted previously.